

**Maintenance-free  
metal-seated  
globe valves**

with bellows

<b>Grey cast iron</b>	<b>PN 16</b>	<b>DN 15-300</b>
<b>Nodular cast iron</b>	<b>PN 16</b>	<b>DN 15-350</b>
<b>Nodular cast iron</b>	<b>PN 25</b>	<b>DN 15-150</b>

### Application

- Hot-water heating systems DIN 4751
- High temperature hot-water heating systems DIN 4752
- Heat transfer systems DIN 4754
- Pressure vessel equipment to TRB 801 no. 45 <sup>1)</sup>
- Steam boiler installations to TRD 108/110 <sup>1)</sup>
- Other fluids on request

<sup>1)</sup> Please contact KSB for limitations imposed by the applicable technical codes.

### Operating data

- Temperature range:
  - 10 up to +300 °C for EN-GJL-250, JL 1040
  - 10 up to +350 °C for EN-GJS-400-18-LT, JS 1025
- Max. operating pressure: up to 16 bar  
(up to 25 bar for EN-GJS-400-18-LT, JS 1025)

### Materials

#### Body:

- Straight-way pattern:
  - Lamellar graphite cast iron EN-GJL-250, JL 1040 \*)
  - Nodular cast iron EN-GJS-400-18-LT, JS 1025 \*)
- Angle pattern:
  - Lamellar graphite cast iron EN-GJL-250, JL 1040 \*)
- For further details see table of materials

### Design

- Straight-way or angle pattern with straight seat
- Throttling plug up to DN 100 (> DN 100: on/off plug)
- Position indicator, locking device and travel stop for all valve sizes
- Compact bonnet
- Maintenance-free stem sealed by bellows and back-up gland packing
- Non-rising handwheel
- Flanges to DIN EN 1092-2 type 21
- Free from asbestos, PCB and CFC
- Exterior finish: blue RAL 5002

The valves meet the safety requirements of the Pressure Equipment Directive 97/23/EC (PED) of annex I for fluids of the groups 1 and 2.

### Standard variants

- Throttling plug for DN > 100
- Plug with PTFE seal ring (max. 200 °C, throttling plugs DN 15-100, on/off plugs DN 125-200)
- Lead-sealable cap against unauthorized closing
- Pilot plug design from DN 200
- Grey aluminium high-temperature resistant paint for applications > 200 °C
- Oil and grease-free design
- Special flange designs
- Bolts having high impact strength at low temperature down to -30 °C (only for JS 1025)
- 3.1 B certification

### Additional information

- Valve characteristics 7150.4
- Chemical resistance chart 7150.2
- Operating instructions 0570.8

### On all inquiries/orders please specify

Globe valve

1. BOA®-H according to type series booklet 7150.1
2. PN 16 or PN 25
3. EN-GJL-250, JL 1040 or EN-GJS-400-18-LT, JS 1025
4. Straight-way or angle pattern (angle pattern only in EN-GJL-250, JL 1040)
5. DN 15-350 (DN 350 only in EN-GJS-400-18-LT, JS 1025)
6. Standard variants

The valves do not have a potential internal source of ignition and can be used in potentially explosive atmospheres, group II, category 2 (zones 1+21) and category 3 (zones 2+22) according to ATEX 94/9/EC.



## Test and operating pressures

Nominal pressure	Material	Body pressure test in bar with water 1) bar	Seat leakage with water 2) bar	Pressure / Temperature ratings <sup>3)</sup>				
				- 10 up to + 120 °C	200	250	300	350
16	EN-GJL-250	24	16	16	12.8	11.2	9.6	-
	EN-GJS-400-18-LT			16	14.7	13.9	12.8	11.2
25	EN-GJS-400-18-LT	37.5	25	25	23	21.8	20	17.5

1) DIN EN 12266-1 (P10, P11)

2) DIN EN 12266-1 (P12 leak rate A)

3) Intermediate temperatures can be derived by linear interpolation.

Please note: DIN EN 1092-2, para. 5.3, AD W7, TRD 106 and plant-specific regulations must be observed when selecting connecting elements between the valve flanges and the pipeline flanges.

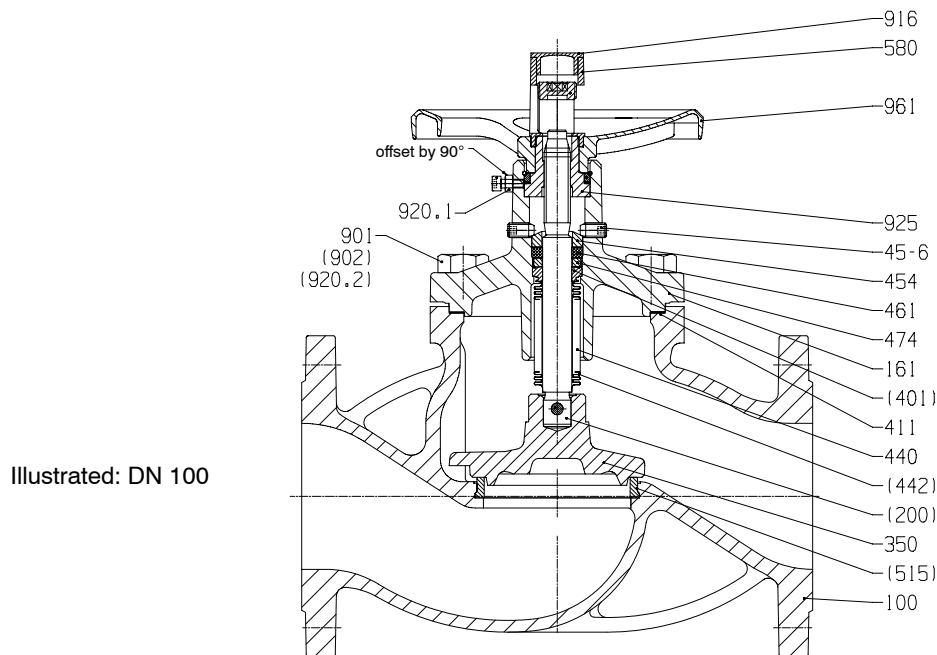

## Materials

Part No.	Description	DN	Material/Material designation	Material No.
100	Body	15-300	EN-GJL-250	JL1040
		15-350	EN-GJS-400-18-LT	JS1025
161	Bonnet	15-300	EN-GJL-250	JL1040
		15-350	EN-GJS-400-18-LT	JS1025
350	Valve plug	15-150	X 20 Cr 13	1.4021+QT (1.4021)
		200-350	C 22 / X 15 CrNi 18 8	1.0402 / 1.4370
411	Gasket		CRNiSt-graphite	
440	Bellows set comprising:			
200	Stem		Stainless steel (min. 13% Cr)	
401	Welding ring		Stainless steel	
442	Bellows		X 6 CrNiTi 18 10	1.4541
454	Gland ring		Stainless steel	
45-6	Gland bolt		Steel	
461	Gland packing		Pure graphite	
474	Thrust ring		Stainless steel	
515	Seat ring		Stainless steel	
543	Spacer bush	15-65	Glass fibre reinforced plastic	
580	Cap	15-150	Glass-fibre reinforced plastic, impact resistant	
		200-350	Steel	
901	Hex. head bolt		8.8 for EN-GJL-250	
902	Stud		CK 35 V for EN-GJS-400-18-LT	
920	Hex. nut		C35 for EN-GJS-400-18-LT	
916	Plug		Plastic	
925	Stem nut		Steel, coated	
961	Handwheel	15-150	Aluminium die-cast	
		200-350	EN-GJL-250	JL1040

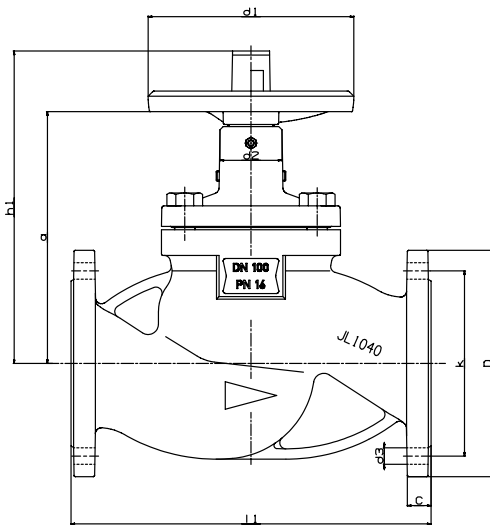
**Dimensions PN 16**

Straight-way pattern

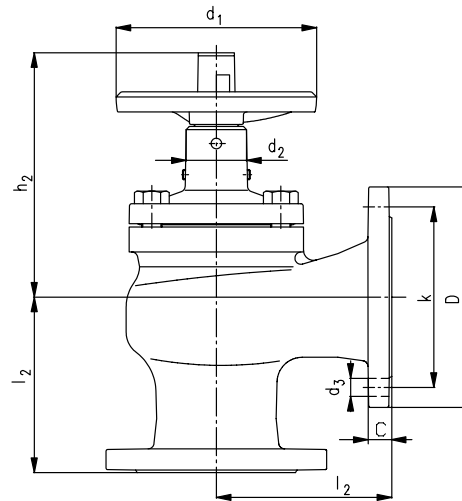

Angle pattern

 a and d<sub>2</sub> insulation dimensions

Dimensions (mm)													Weight approx.	
PN	DN	l <sub>1</sub>	l <sub>2</sub>	h <sub>1</sub>	h <sub>2</sub>	d <sub>1</sub>	d <sub>2</sub>	a	D	k	n x d <sub>3</sub>	C	Straight-way pattern	Angle pattern
													kg	kg
16 JL1040	15	130	90	175	150	125	47	137	95	65	4 x 14	14	3.1	3.2
	20	150	95	178	153	125	47	140	105	75	4 x 14	16	4.0	4.0
	25	160	100	184	151	125	47	146	115	85	4 x 14	16	4.7	4.8
	32	180	105	205	170	125	47	161	140	100	4 x 19	18	7.3	7.5
	40	200	115	210	172	125	47	166	150	110	4 x 19	18	7.7	7.7
	50	230	125	235	198	160	51	190	165	125	4 x 19	20	10.2	9.6
	65	290	145	246	198	160	51	201	185	145	4 x 19	20	17.0	16.3
	80	310	155	282	226	200	60	223	200	160	8 x 19	22	22.0	21.8
	100	350	175	304	244	200	60	245	220	180	8 x 19	24	32.0	30.8
	125	400	200	390	316	250	80	310	250	210	8 x 19	26	54.0	48.3
	150	480	225	408	320	250	80	328	285	240	8 x 23	26	70.5	65.7
	200	600	275	570	468	400	93	440	340	295	12 x 23	30	130.0	114.2
250	730	325	606	480	400	93	476	405	355	12 x 28	32	230.0	180.5	
300	850	375	660	510	400	93	530	460	410	12 x 28	32	328.0	267.5	
16 JS1025	15	130	-	175	-	125	47	137	95	65	4 x 14	14	3.1	-
	20	150	-	178	-	125	47	140	105	75	4 x 14	16	4.1	-
	25	160	-	184	-	125	47	146	115	85	4 x 14	16	4.6	-
	32	180	-	205	-	125	47	161	140	100	4 x 19	18	8.1	-
	40	200	-	210	-	125	47	166	150	110	4 x 19	18	8.5	-
	50	230	-	235	-	160	51	190	165	125	4 x 19	20	11.0	-
	65	290	-	246	-	160	51	201	185	145	4 x 19	20	17.0	-
	80	310	-	282	-	200	60	223	200	160	8 x 19	22	21.0	-
	100	350	-	304	-	200	60	245	220	180	8 x 19	24	31.0	-
	125	400	-	390	-	250	80	310	250	210	8 x 19	26	51.0	-
	150	480	-	408	-	250	80	328	285	240	8 x 23	26	68.5	-
	200	600	-	570	-	400	93	440	340	295	12 x 23	30	139.0	-
250	730	-	606	-	400	93	476	405	355	12 x 28	32	239.0	-	
300	850	-	660	-	400	93	530	460	410	12 x 28	32	343.0	-	
350	980	-	660	-	400	93	530	520	470	16 x 28	36	390.0	-	

**Dimensions PN 25**

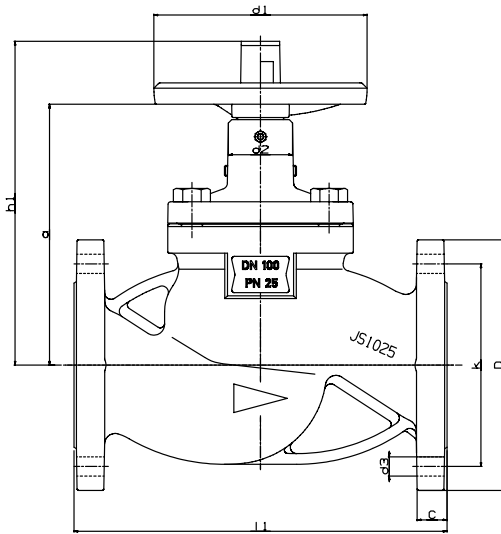

a and d<sub>2</sub> insulation dimensions

Dimensions (mm)											Weight approx.
PN	DN	l1	h1	d1	d2	a	D	k	n x d3	C	Straight-way pattern
											kg
25 JS1025	15	130	175	125	47	137	95	65	4 x 14	14	3.1
	20	150	178	125	47	140	105	75	4 x 14	16	4.1
	25	160	184	125	47	146	115	85	4 x 14	16	4.6
	32	180	205	125	47	161	140	100	4 x 19	18	8.2
	40	200	210	125	47	166	150	110	4 x 19	18	8.5
	50	230	235	160	51	190	165	125	4 x 19	20	11.0
	65	290	246	160	51	201	185	145	8 x 19	20	17.0
	80	310	282	200	60	223	200	160	8 x 19	22	28.9
	100	350	304	200	60	245	235	190	8 x 23	24	40.0
	125	400	390	250	80	310	270	220	8 x 28	26	65.0
150	480	408	250	80	328	300	250	8 x 28	26	89.0	

**Installation instructions**

The flow direction in BOA<sup>®</sup>-H shut-off globe valves should correspond to the embossed arrow on the body. An alternating flow direction is permissible for the standard valve plug, but not for the throttling plug. If the following differential pressures are exceeded on valves with standard valve plugs from DN 200 upwards, a pilot plug design is required. The pilot plug only takes effect if there is a pressure build-up on the outlet side. Valves with throttling plugs can only be used up to these differential pressures.

	DN	150	200	250	300/350
PN 16	Δp bar	-	12	9	6
PN 25		21			

**Connection dimensions - Standards:**

Flanges: DIN EN 1092-2, flange type 21 - JL1040  
 flange type 21-21 - JS1025  
 Flange facing: DIN EN 1092-2, type B

**Face-to-face dimensions**

Straight-way pattern: EN 558-1/1 (previously: DIN 3202/F 1)  
 ISO 5752/1  
 Angle pattern: EN 558-1/8 (previously: DIN 3202/F 32)  
 ISO 5752/8

Product features - to our customers' Benefit (1)

**Non-rotating stem, protected external thread**

**Your benefit**

- High operating reliability

**Bellows welded to the stem**

**Your benefit**

- No vibrations transmitted from plug to bellows

**Standard-equipped throttling plug up to DN 100**

**Your benefit**

- Flow regulation at any time and at no extra cost

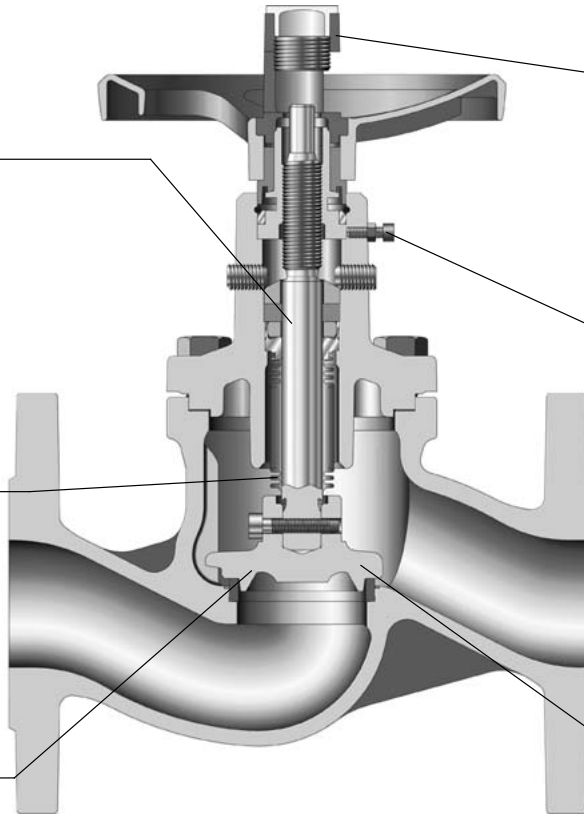

**Standard-equipped position indicator with travel stop located outside the insulation**

**Your benefit**

- Position of valve plug can be identified at any time
- Valve can be exactly set to its original position after closing

**Standard-equipped locking device**

**Your benefit**

- Protection against accidental valve actuation

**Replaceable plug**

**Your benefit**

- Reduced maintenance cost as the valve plug can be replaced without having to replace the entire bonnet

Variants

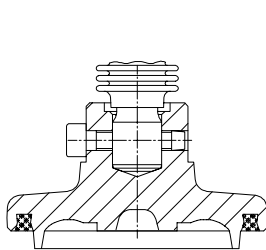

Throttling plug with PTFE seal ring, DN 15-100

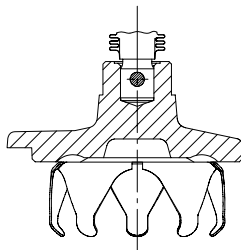

Throttling plug from DN 125

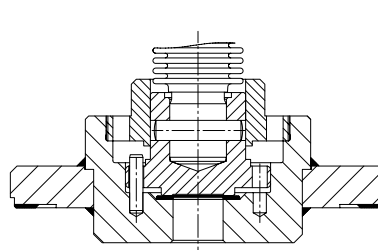

Pilot plug design from DN 200

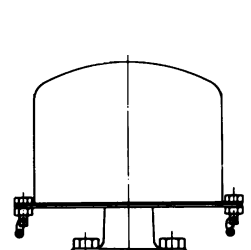

Lead-sealable cap

## Product features - to our customers' Benefit (2)

### Colour coded position indicator

#### Your benefit

- Valve plug type can be identified externally, without removing the insulation
- Guards against incorrect plug replacement

### Non-rising handwheel

#### Your benefit

- Ideal in confined spaces

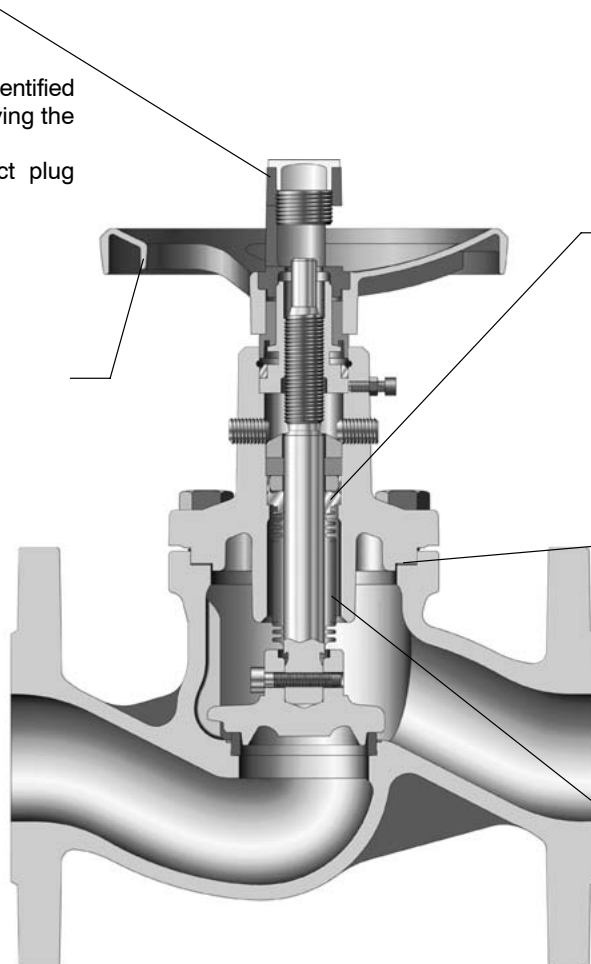

### Back-up gland packing of pure graphite, e. g. for heat transfer systems to DIN 4754

#### Your benefit

- Extra safety in the event of a bellows failure

### Fully confined bonnet gasket

#### Your benefit

- Gasket cannot creep out of joint, longer gasket life

### Protected bellows when valve is fully open

#### Your benefit

- Bellows protected against pressure surges

Subject to technical modification without prior notice

## Colour coding system

Blue plug:  
on/off plug

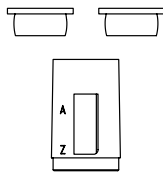

Crimson red  
cap:

metal-seated plug

White plug:  
throttling plug

Blue plug:  
on/off plug

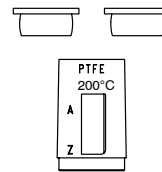

Blood orange  
cap:

Design:  
plug with PTFE gasket

White plug:  
throttling plug